

In-hand & Liberty Green Training

1. Walk to centre, horse at shoulder, turn left and halt at X
2. Walk 1 circle to Left with horse at shoulder
3. Trot 1 circle to Left with horse at shoulder
4. Halt at X
5. Back 4 steps
6. Walk 1 circle to Right with horse at shoulder
7. Trot 1 circle to Right with horse at shoulder
8. Halt at X

Exit arena

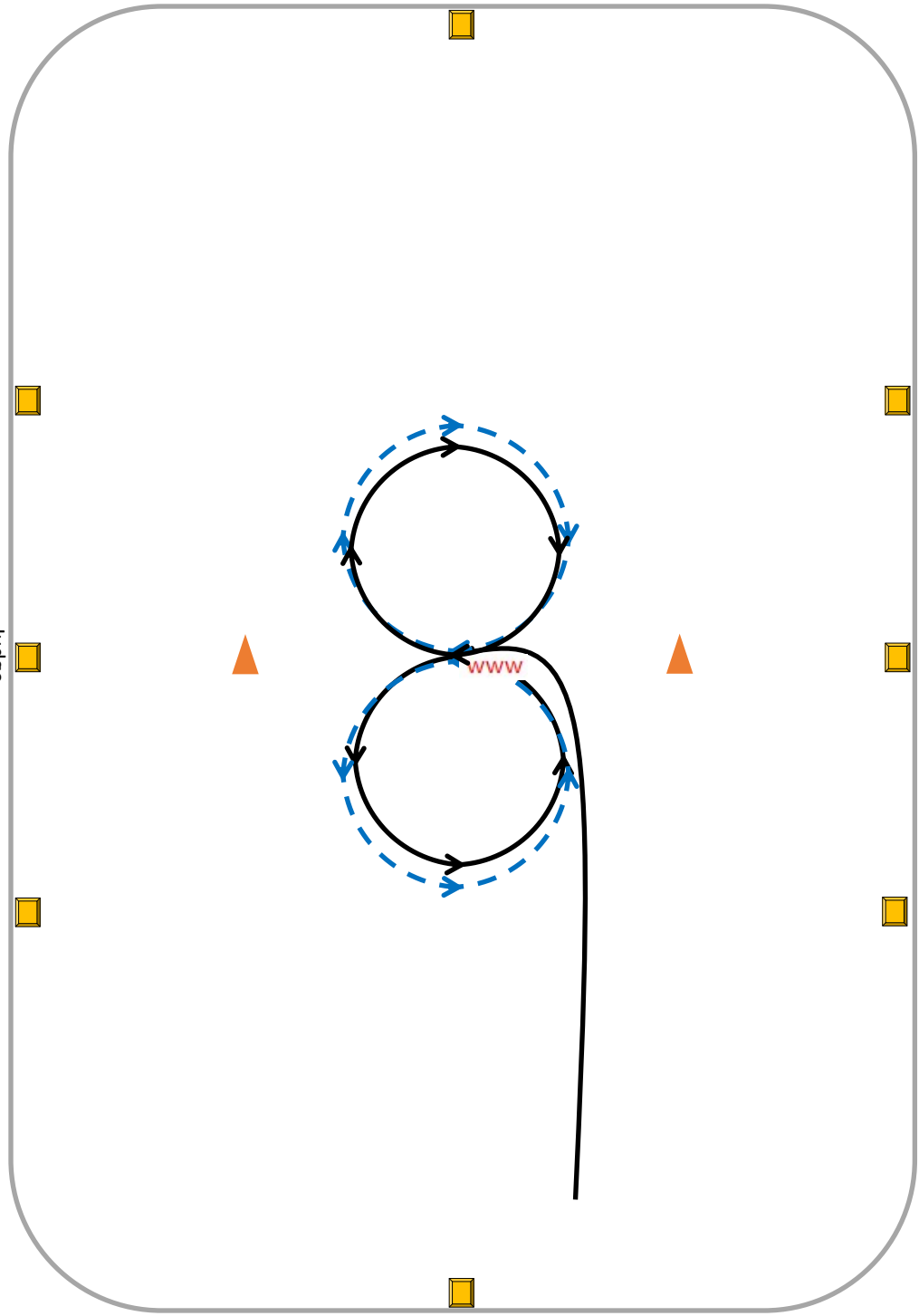

Legend

Walk		Back	
Trot/Jog		Sidepass	
Canter/Lope			

In-hand & Liberty Level 1

1. Jog to centre, horse at shoulder, turn left and halt at X
2. Back – 4 steps
3. Trot 1 circle to Left with horse at shoulder
4. Trot 1 circle to Left sending horse around handler
5. Halt at X
6. Walk 1 ½ circles around horse demonstrating ground tie
7. Trot 1 circle to Right with horse at shoulder
8. Trot 1 circle to Right sending horse around handler
9. Halt at X
10. Turn horse 360 (in either direction)

Exit arena

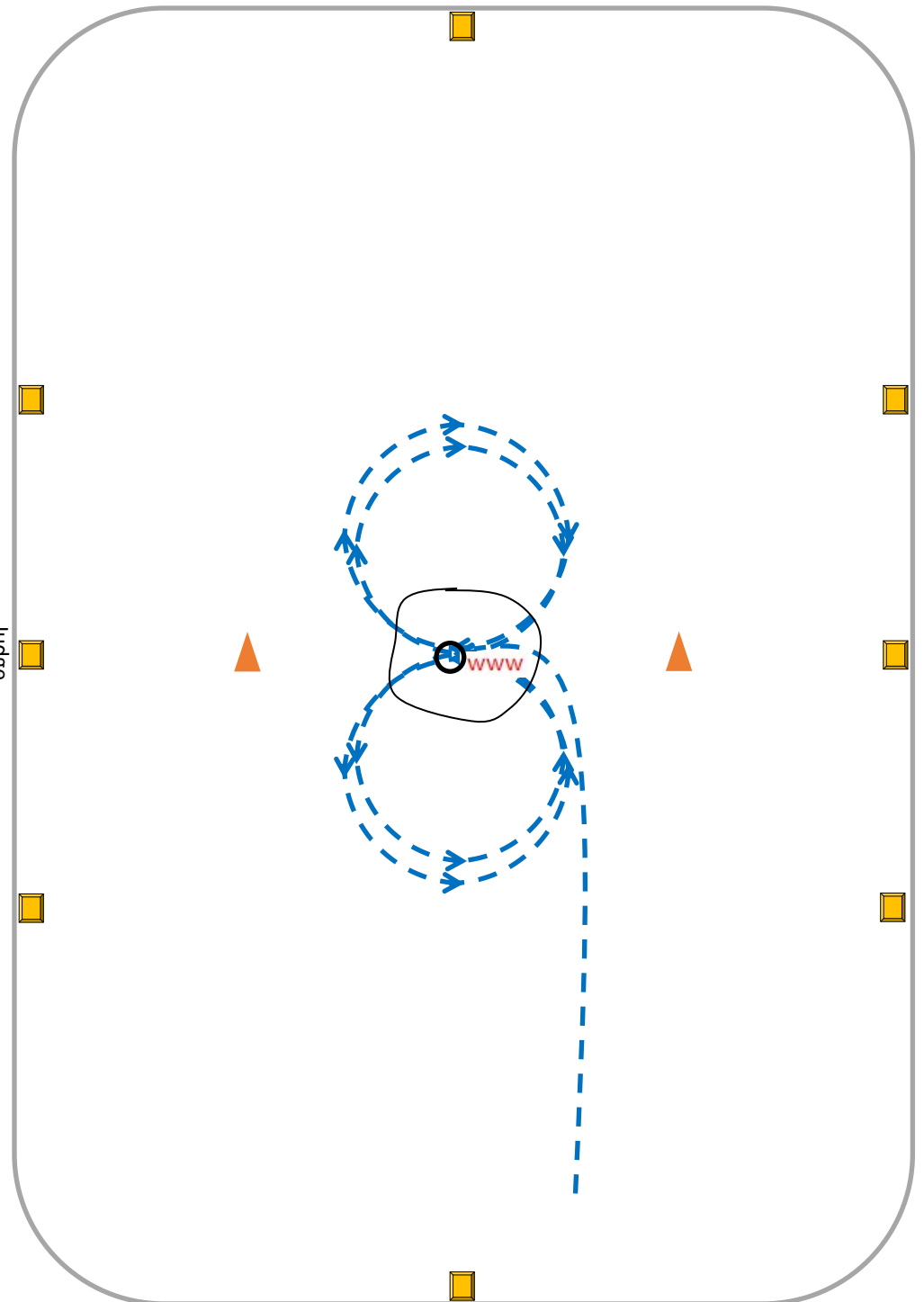

Legend

Walk ———
 Trot/Jog - - - -
 Canter/Lope - - - -

Back www
 Sidepass uu
 uu

In-hand & Liberty Level 2

1. With horse at shoulder, trot up centre line and halt just beyond X
2. Back at least 4 steps to centre X
3. Yield hindquarters to Left 270°, yield shoulders 180° Left
4. With horse at Left shoulder, walk figure 8 around pylon to Right, at X switching horse to Right shoulder and continue walking around pylon to Left
5. At X, trot 1 small circle to Left with horse at shoulder
6. Canter 2 large circles to Left sending horse around handler
7. Halt at X
8. Sidepass horse 4 steps away from handler and then 4 steps toward handler
9. Trot 1 small circle to Right with horse at shoulder
10. Canter 2 large circles to Right sending horse around handler
11. Halt at X
12. Handler walk away toward centre pylon and call horse

Exit arena



Judge

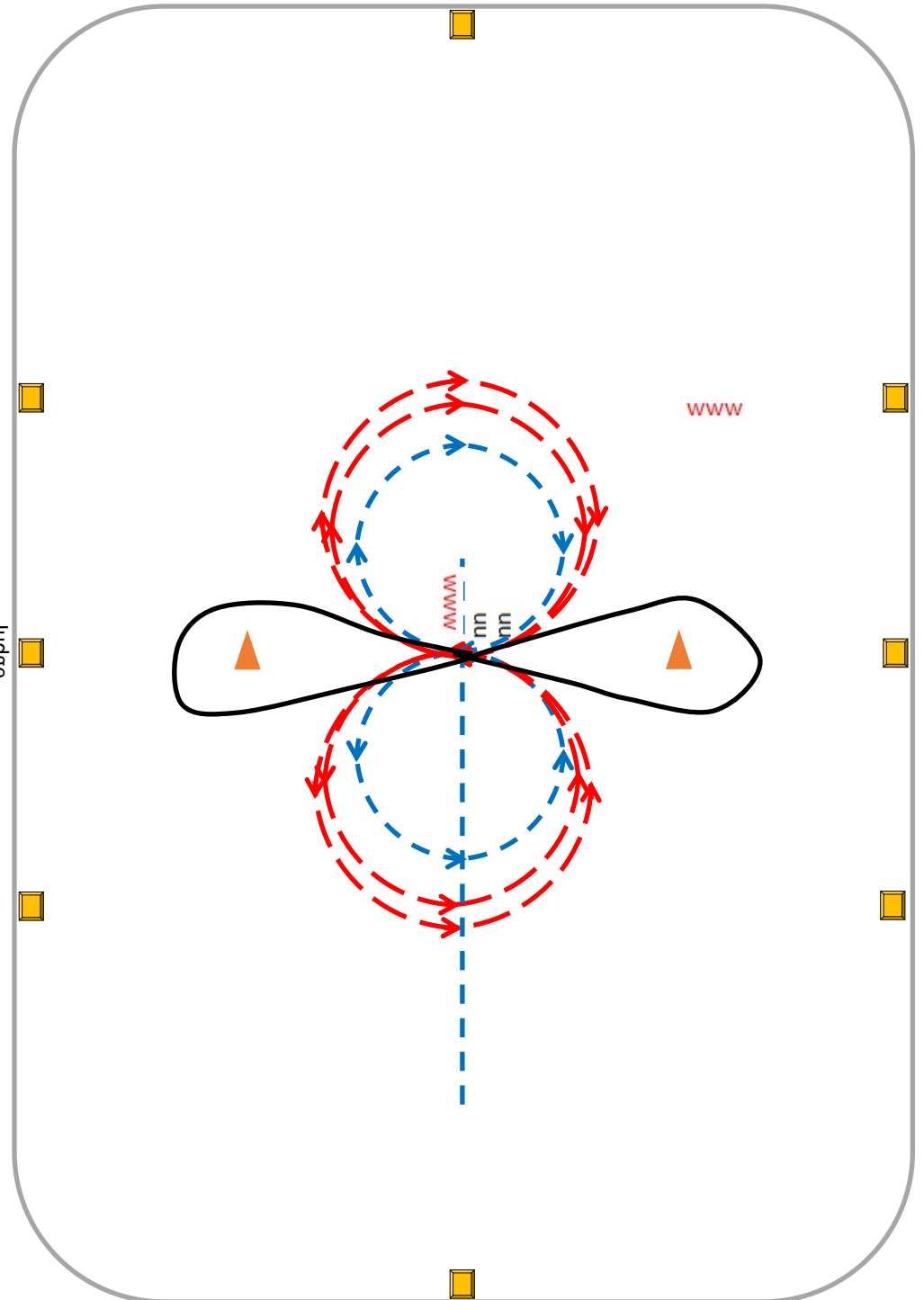

Legend

Walk		Back	
Trot/Jog		Sidepass	
Canter/Lope			

In-hand & Liberty Level 3

1. Begin with horse ground tie and handler walking to centre X and call horse to you
2. Trot 2 small circles to Left sending horse around handler
3. Canter 2 large circles to the Left sending horse around handler
4. At X change directions
5. Trot 2 small circles to Right sending horse around handler
6. Canter 2 large circles to the Right sending horse around handler
7. Halt at X
8. Lay horse down, pause 5 seconds and ask horse to stand
9. Send horse around pylons completing 2 figure 8s at trot
10. Halt at X
11. Sidepass horse 4 steps Left and then 4 steps Right
12. Back 4 steps

Exit arena

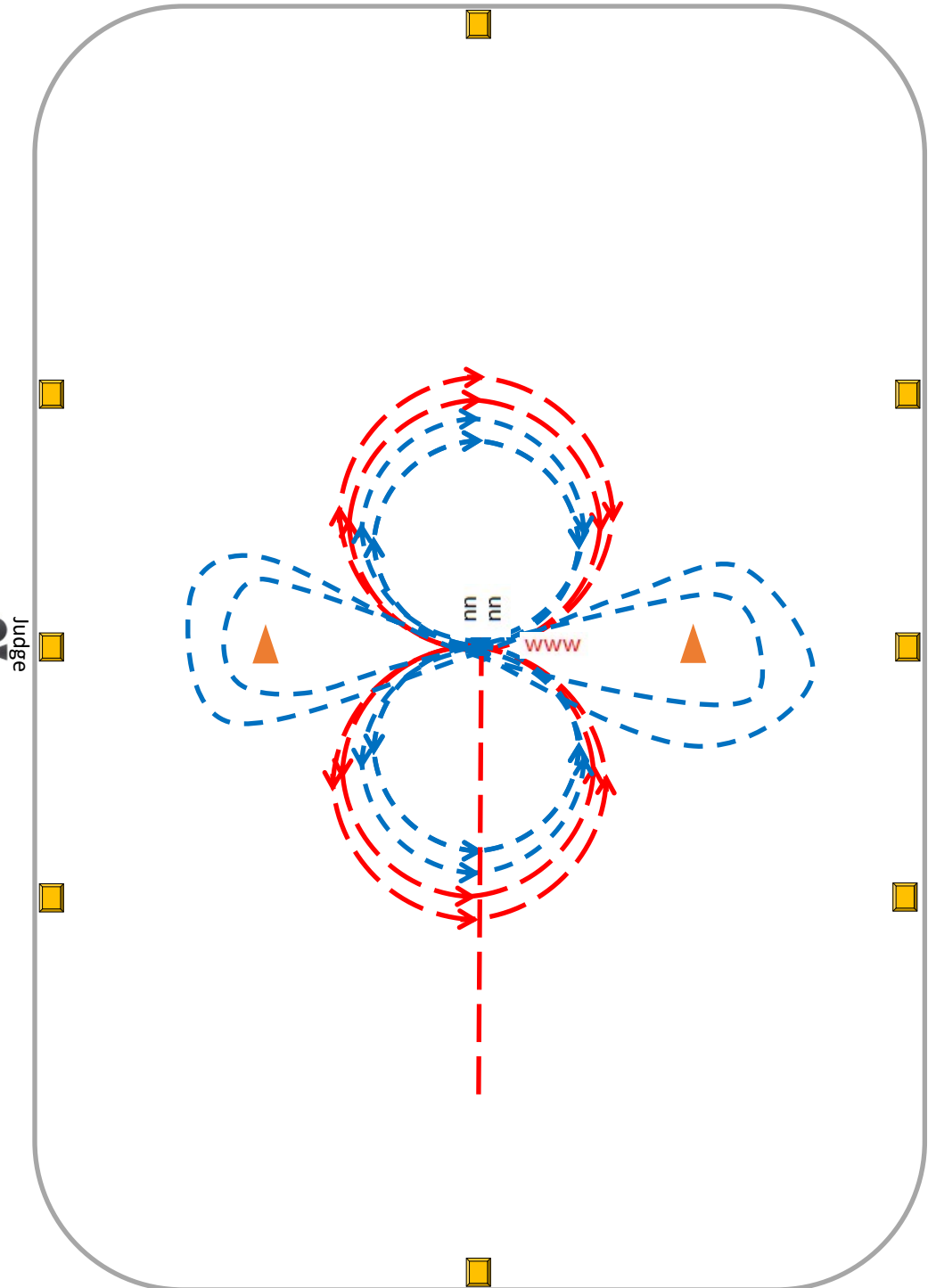

Legend

Walk ———
 Trot/Jog - - - -
 Canter/Lope - - - -

Back www
 Sidepass uu
 uu

Bridleless Green Training

1. Walk past end arena marker, and serpentine to centre X
2. Halt at X facing judge
3. Turn 1/4 Right and walk Right circle around pylon
4. Halt at X
5. Walk Left circle around pylon
6. Halt at X and turn 1/4 Left facing judge
7. Trot serpentine to centre arena marker
8. Halt and Back 4 steps, pause

Exit arena

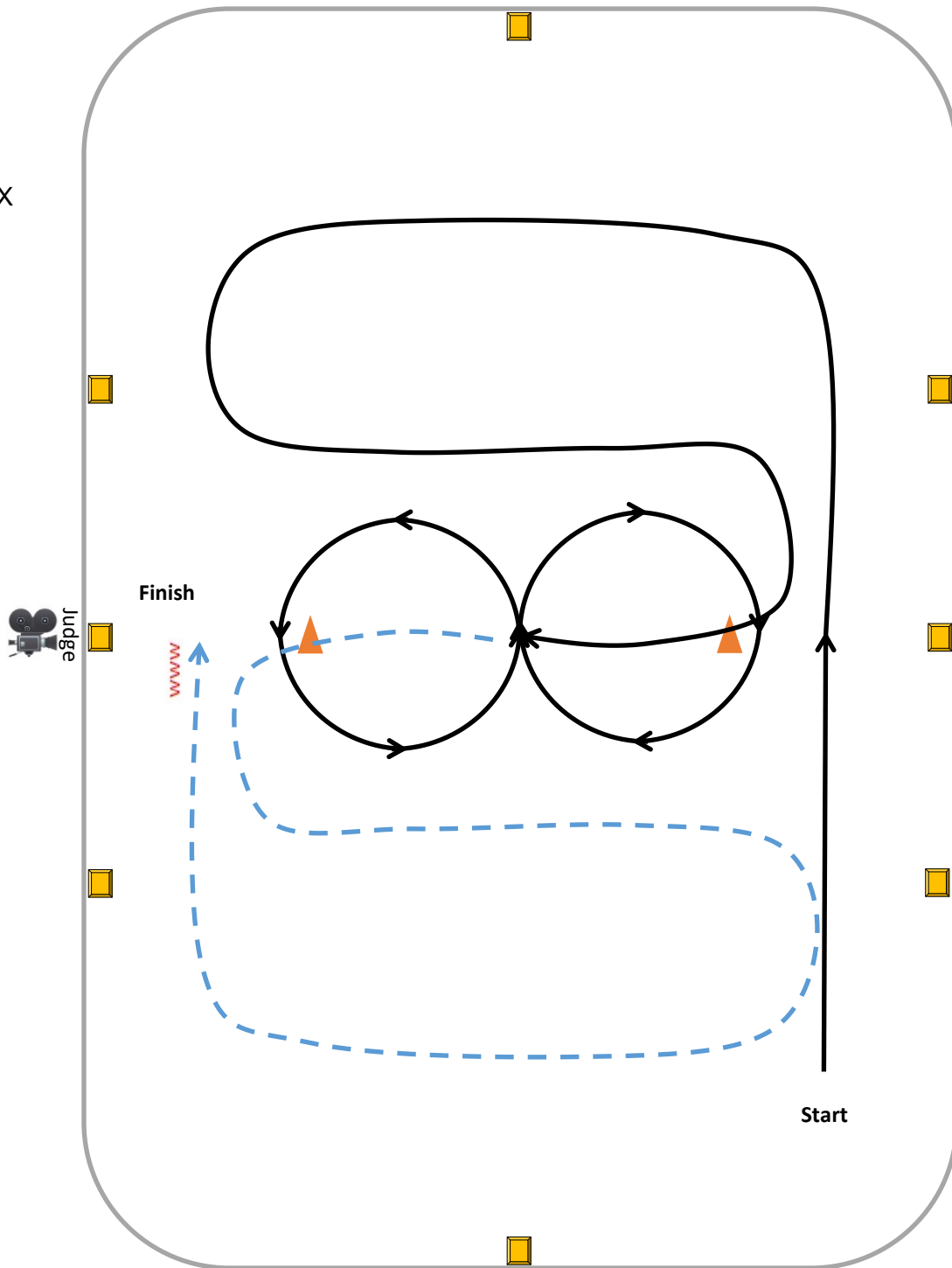

Legend

Walk		Back	
Trot/Jog		Sidepass	
Canter/Lope			

Bridleless Level 1

1. Walk to centre marker
2. Walk 1 1/2 circle Left around pylon
3. At X Trot 1 1/2 circle Left around pylon
4. Trot up rail past end arena marker and serpentine to centre X
5. Halt at X and turn 1/4 to Left
6. Walk 1 circle Right around pylon
7. At X Trot 1 circle Right around pylon and continue straight
8. Halt at end arena marker
9. Turn horse 360 (either direction)
10. Back 4 steps, pause

Exit arena

Clarification: for this pattern, maneuver #2, the circle starts as you cross the centre marker and begin the circle



Legend

Walk		Back	
Trot/Jog		Sidepass	
Canter/Lope			

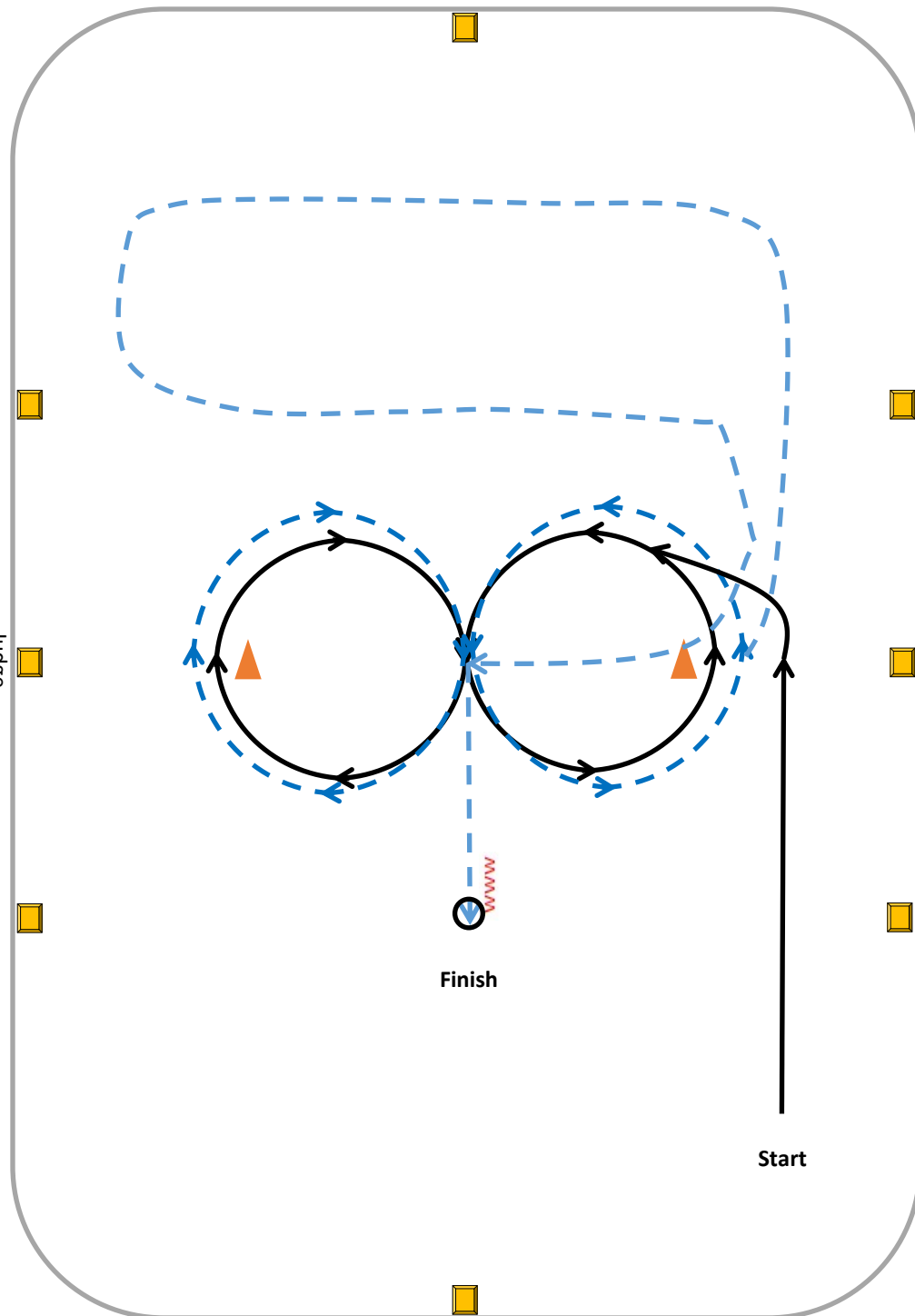

Bridleless Level 2

1. Walk to centre arena marker
2. Trot 2 1/2 circle Left around pylon
3. Halt at X
4. Sidepass Left 4 steps
5. Sidepass Right 4 steps
6. Trot 2 1/2 circle Right around pylon
7. Canter Right up rail past end arena marker, circling Right diagonally to X
8. At X break to Trot continuing on the diagonal until end arena marker and Halt
9. Complete 1 turn haunches Left
10. Complete 1 turn haunches Right

Exit arena



Judge

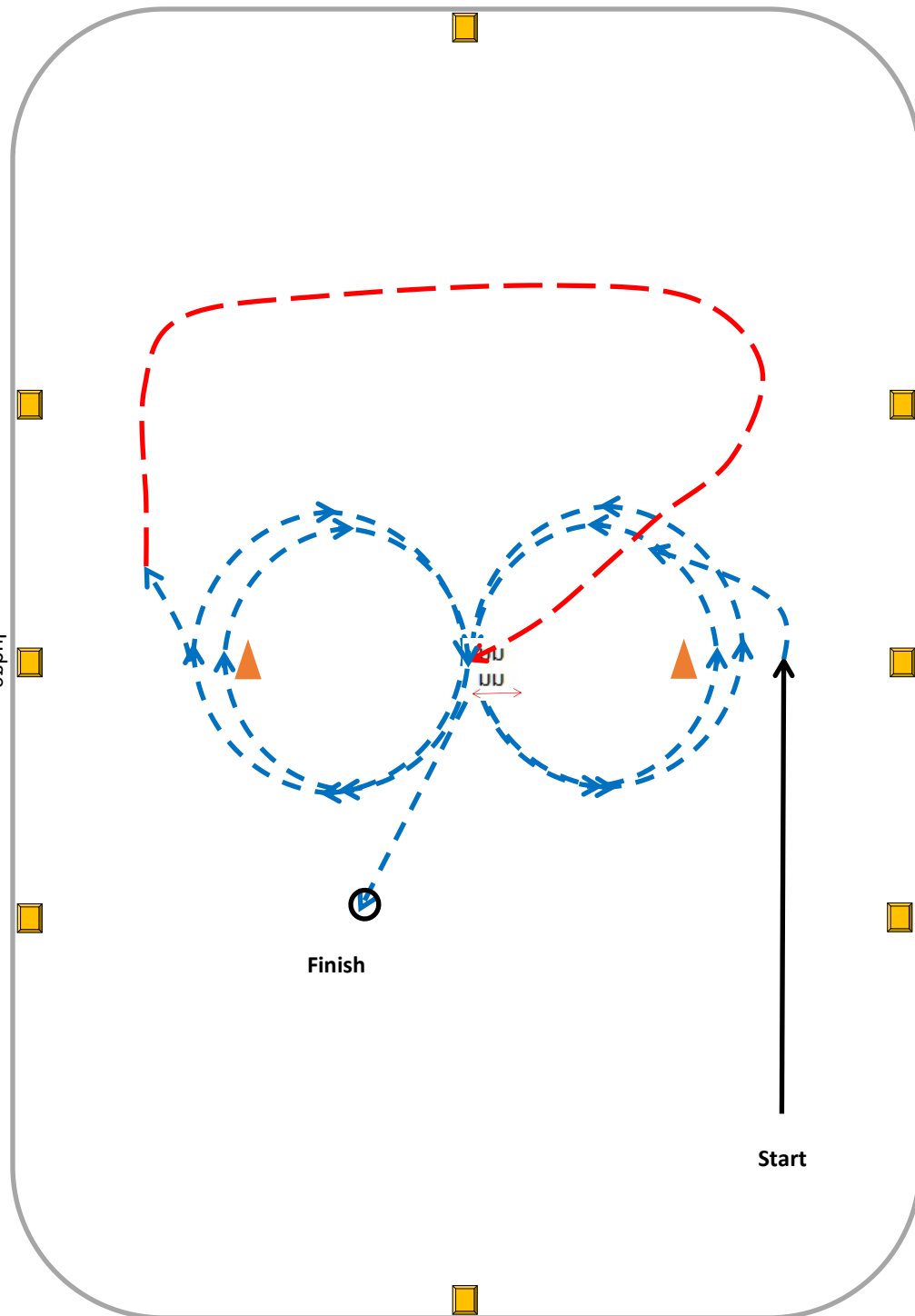

Legend

Walk ———
 Trot/Jog - - - -
 Canter/Lope - - - -

Back www
 Sidepass uu
 uu

Bridleless Level 3

1. Trot to centre arena marker
2. Trot 2 1/2 circle Left around pylon
3. Change directions at X
4. Trot 2 circle Right around pylon
5. Continue through X straight to end arena marker, and halt
6. Complete 2 turn haunches Left
7. Complete 2 turn haunches Right
8. Canter Left 1 1/2 large circle
9. Change leads (simple or flying) at X
10. Canter Right 2 large circle
11. Halt at X
12. Back 4 steps

Exit arena



Legend

Walk		Back	
Trot/Jog		Sidepass	
Canter/Lope			

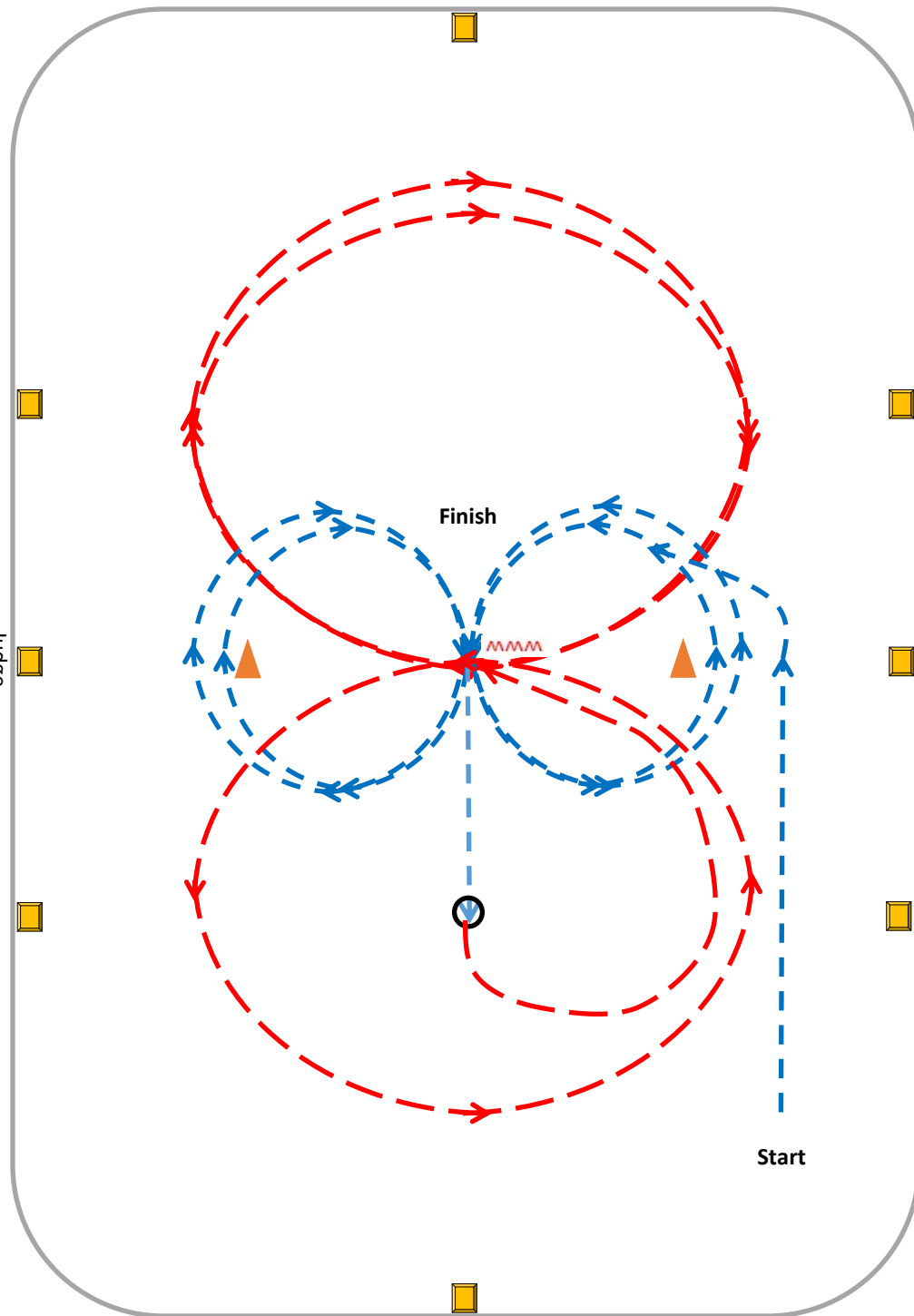

In-hand & Liberty Obstacles Green Training

1. Weave through boots at walk
2. Walk into chute and back out
3. Walk over tarp- 4. Walk over top two poles
- 5. Walk into square and halt
- 6. Handler walk around outside of box one full circle
- 7. Turn horse around 360 inside box
- 8. Walk to and over bridge

Exit arena

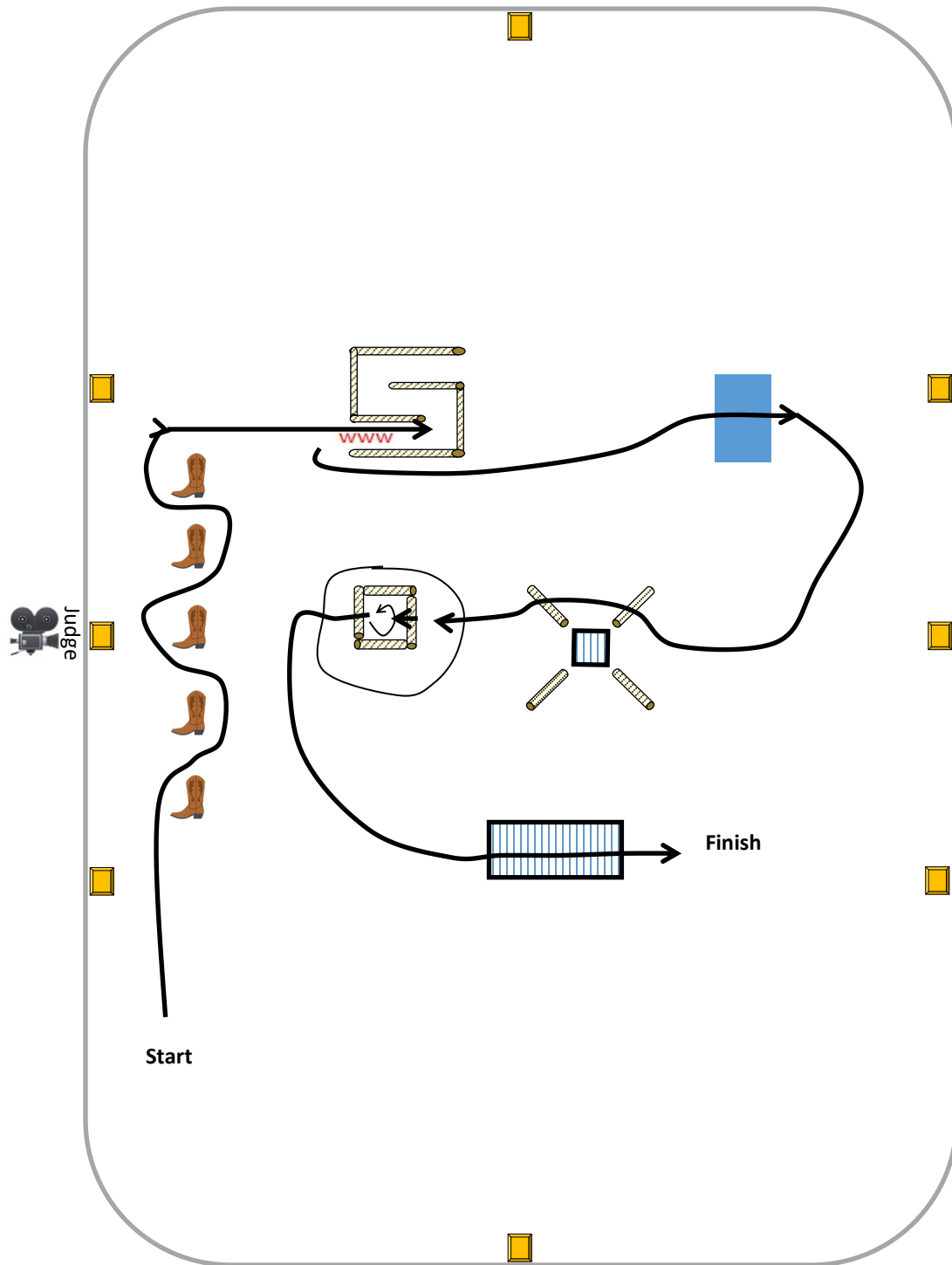

Legend

Walk		Back	
Trot/Jog		Sidepass	
Canter/Lope			

In-hand & Liberty Obstacles Level 1

1. Weave through boots at walk
2. Walk into chute and turn Left 90 and walk over poles
3. Walk over tarp- 4. Walk over poles completing 1 1/2 circle
- 5. Walk into square and halt
- 6. Turn horse around 360 Left
- 7. Turn horse around 360 Right
- 8. Trot to and walk over bridge

Exit arena

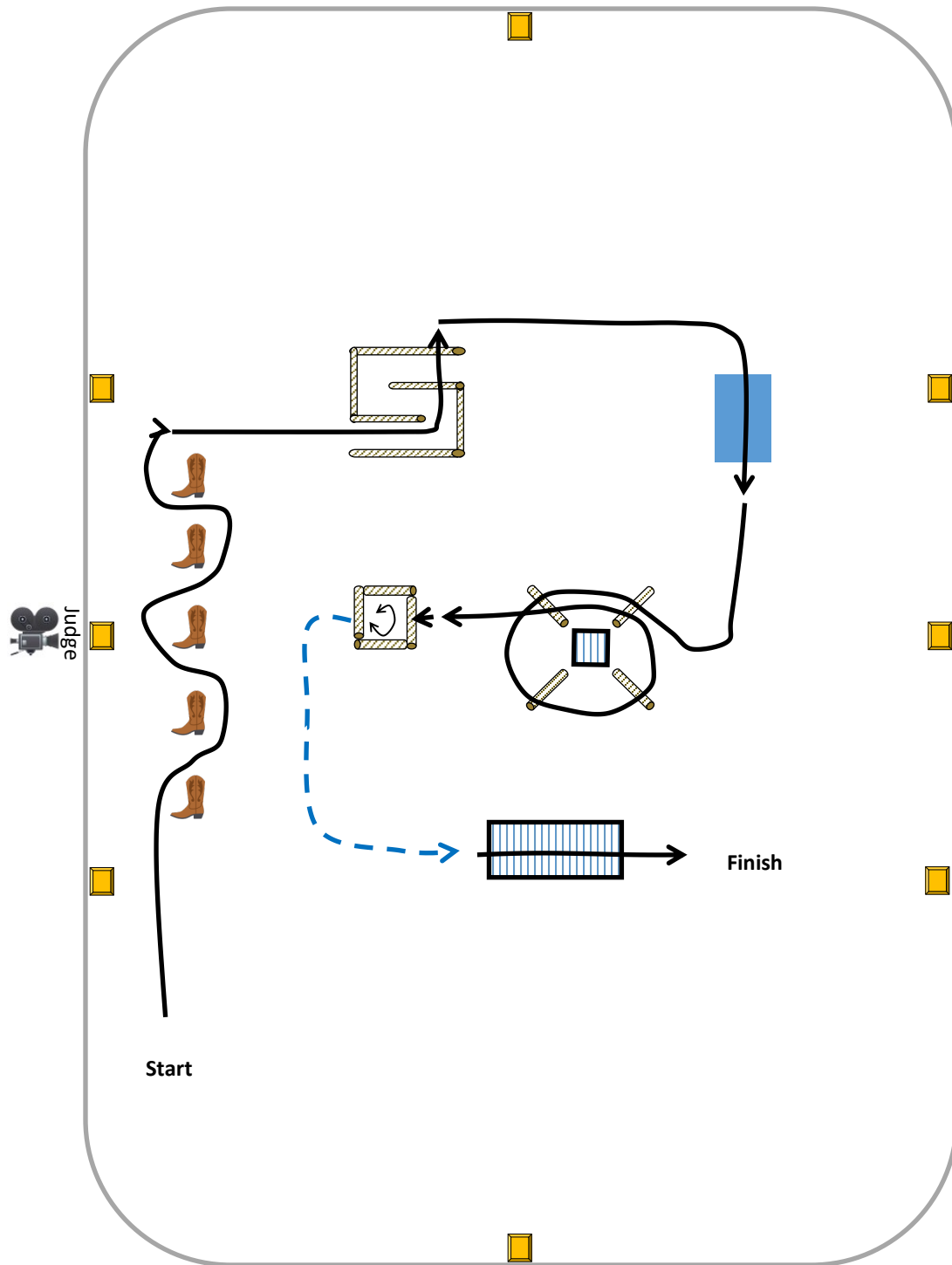

Legend

Walk		Back	
Trot/Jog		Sidepass	
Canter/Lope			

In-hand & Liberty Obstacles Level 3

1. Weave through boots at trot
2. Walk through S, handler to remain on outside of poles
3. Trot to tarp and walk over
4. Step on box, turn 90 Right and step off
5. Handler stands on box, send horse at trot one circle Left over poles, change direction and one circle Right
6. Sidepass horse to handler
7. Walk into square and halt
8. Handler walk around outside of box one full circle
9. Keeping horse in square, handler walk toward bridge, call horse to you
10. Walk on bridge 1/2 way, halt and back off

Exit arena

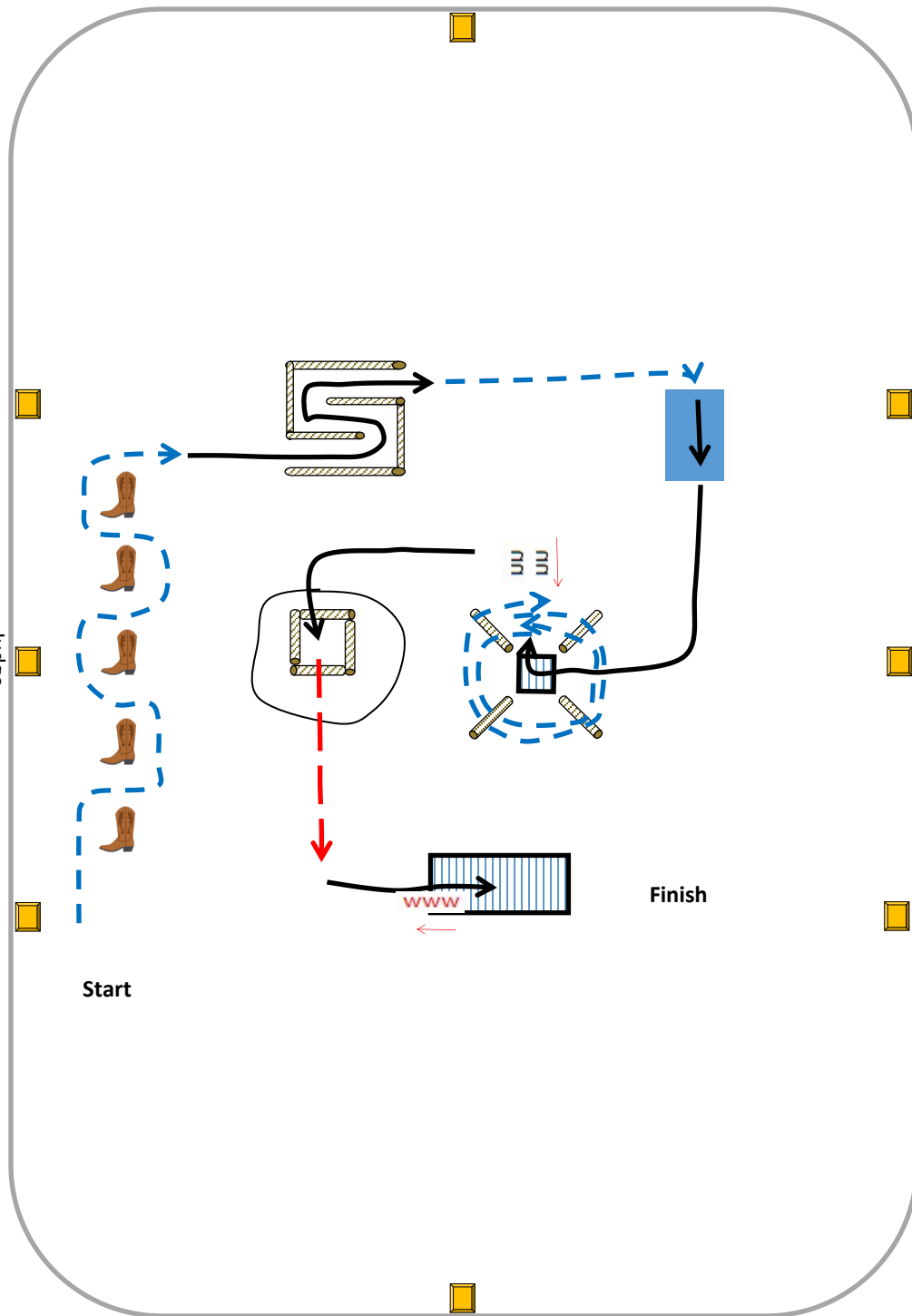

Legend

Walk		Back	
Trot/Jog		Sidepass	
Canter/Lope			

Bridleless Obstacles Green Training

1. Weave through boots at walk
2. Walk into chute and back out
3. Walk over tarp- 4. Walk over top two poles
- 5. Walk into square and halt for 5 seconds
- 6. Walk out of box and walk 1 circle Left around box
- 7. Walk to and over bridge

Exit arena

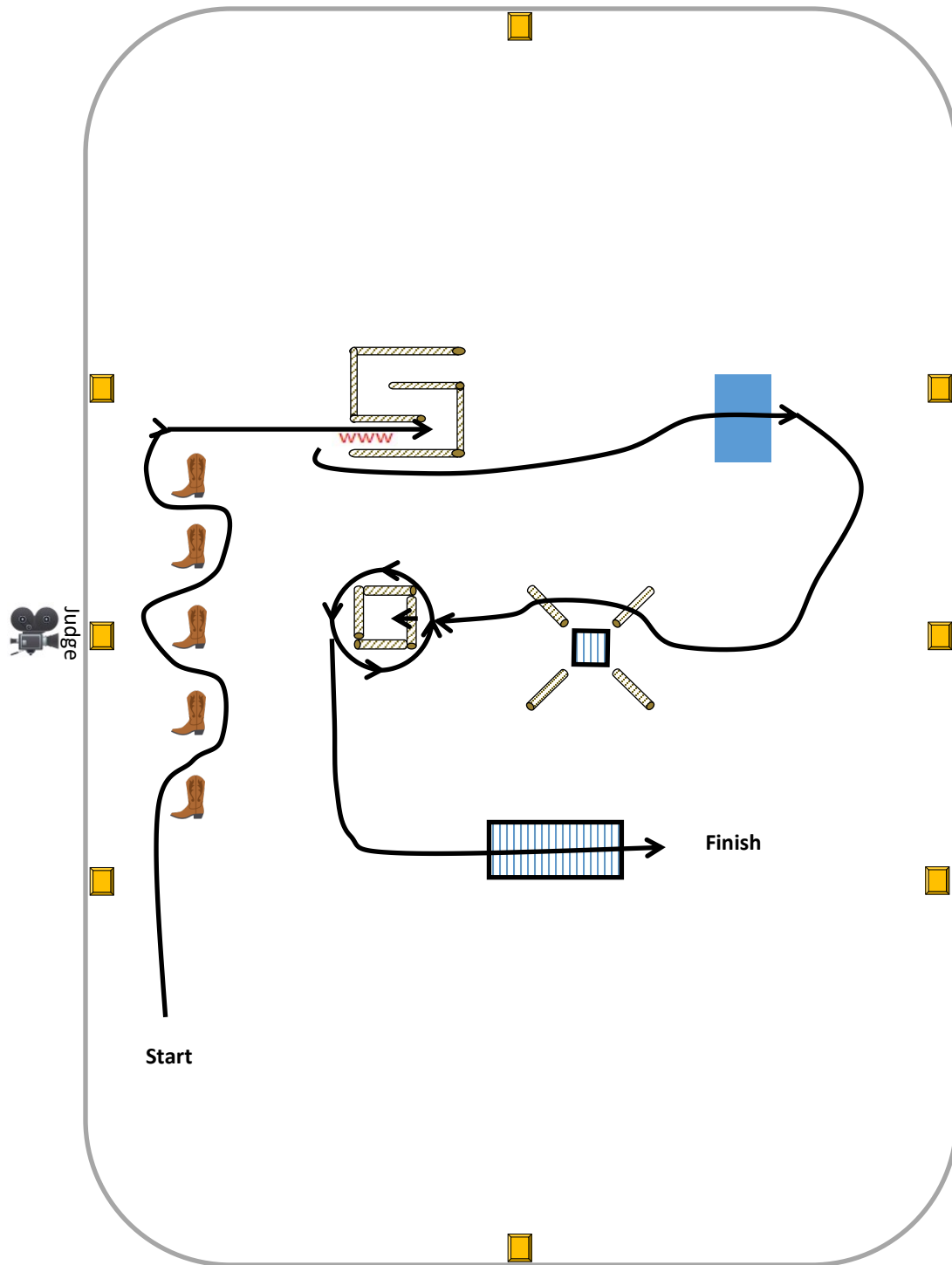

Legend

Walk		Back	
Trot/Jog		Sidepass	
Canter/Lope			

Bridleless Obstacles Level 1

1. Weave through boots at walk
2. Walk into chute and turn Left 90 and walk over poles
3. Walk over tarp- 4. Walk over poles completing 1 1/2 circle
- 5. Walk into square and halt
- 6. Turn horse around 360 Left
- 7. Turn horse around 360 Right
- 8. Trot to and walk over bridge

Exit arena

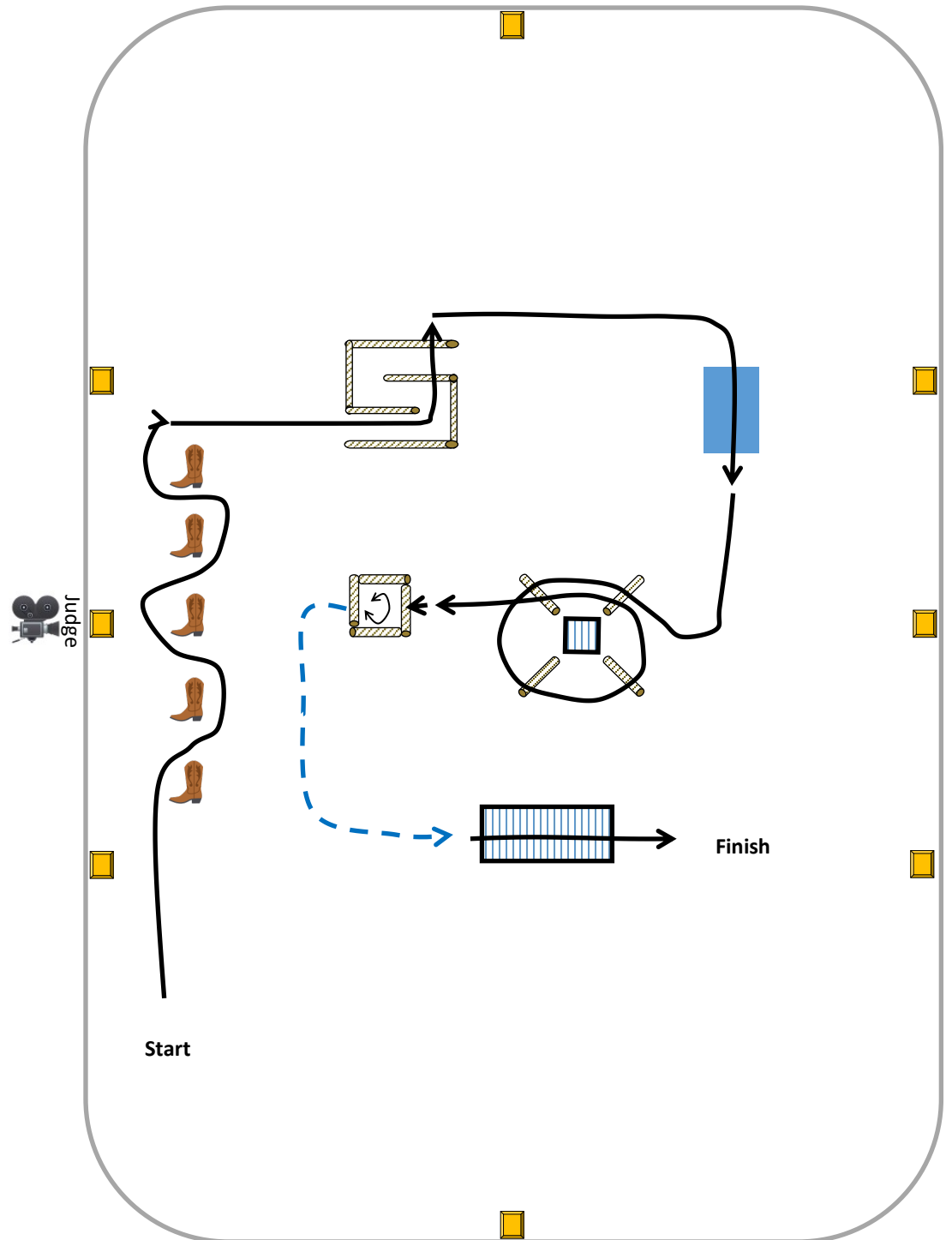

Legend

Walk		Back	
Trot/Jog		Sidepass	
Canter/Lope			

